



HydroTech Water-Source Heat Pump Manual

Overview

Packaged Water-to-Air heat pumps used for residential and commercial applications have been available in the HVAC industry for many years. Packaged units are designed with the compressor, coaxial heat exchanger, air coil, blower section, and controls all in one cabinet. There are two common types of packaged heat pumps, water-to-water and water to air units with the latter the most popular. Water-to-air heat pumps heat or cool air from the conditioned space. First Company manufactures two water-to-air HydroTech heat pump series—the 13.0 EER (Energy Efficiency Ratio) models and 14.0 EER models. Vertical (WSVC & WSVX) and horizontal (WSHC & WSHX) models are available in multiple voltage options and supply / return air configurations. The HydroTech heat pumps are available in multiple capacities ranging from 9,000 BTU's to 60,000 BTU's.



Components

The **compressor** is the “heart” of the HydroTech heat pump units. First Company employs reciprocating compressors for the smaller units up to and including the 3.5 ton models and single-stage scroll compressors for the 4.0 and 5.0 ton models. Compressors are sourced from leading US manufacturers.

The **coaxial heat exchanger** is a water-to-refrigerant heat exchanger that serves two functions. It serves as the condenser in the cooling mode of operation and the evaporator in the heating mode. Coaxial heat exchangers, sometimes referred to as “tube-in-tube heat” heat exchangers, are sourced from a vendor located in the United States. Coaxial heat exchangers are made up of two tubes—one located inside the other. Water passes through the spiraled inner tube creating a turbulent flow of water while increasing surface area to improve heat transfer between the water and refrigerant. Depending on the quality of the water used for the heat pump system, some maintenance is usually required. Without maintenance minerals and other particles in the water may eventually begin to restrict the water flow in the heat exchanger.

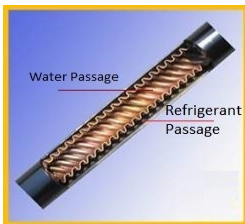

Reversing valves are pilot-operated valves that provide the ability to switch functions of the evaporator coil and the coaxial heat exchanger. The top center connection of the reversing valve is always connected to the compressor suction port, while the bottom connection is connected to the compressor discharge port. The remaining two reversing valve ports provide the heat pump the means to switch from heating to the cooling mode of operation. HydroTech reversing valves are energized in the cooling mode of operation. When energized the valve changes position and directs the hot discharge gas (refrigerant) from the compressor to the coaxial heat exchanger. In the heating mode of operation the reversing valve remains de-energized directing the hot discharge gas (refrigerant) to the air coil, which heats the conditioned space.

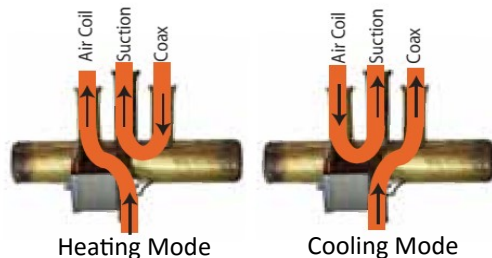

Thermal Expansion Valves (TXV) are another key component found in heat pump systems. The TXV's job is to “meter” the system's refrigerant flow to either the air coil or coaxial heat exchanger depending on the unit's mode of operation. Another responsibility of the TXV is to insure liquid refrigerant doesn't reach the compressor. Since compressors are built to pump only vapor, subjecting the compressor to liquid refrigerant can cause irreparable damage. HydroTech heat pumps employ bi-flow TXV's, which meter refrigerant in both the heating and cooling modes of operation. Bi-flow TXV's are used only on compact/ packaged heat pump units.

As an added precaution **Filter Driers** are installed in the refrigerant system. Filter driers filter refrigerant much like an oil filter filters oil in an automotive engine. Refrigerant filter driers are a vital component of an R-410A refrigerant system as even a drop or two of moisture in the refrigerant system contaminates the system and can cause premature failure of the compressor.

The HydroTech **Air Coils** are manufactured with copper tubing laced with aluminum fins for excellent heat transfer. Air coils operate as an evaporator in the cooling mode of operation and as a condenser in the heating mode. First Company manufactures all of their air coils at the Dallas factory using copper tubing sourced from the United States.

Installation and Operation Instructions

Introduction

The WSV* and WSH* Water-to-Air Heat Pumps are UL listed for zero clearance to combustibles and are designed for vertical and horizontal applications with nominal refrigerant capacities of 9,000 BTUs to 60,000 BTU's. WSV* and WSH* units are heat pump only units. Auxiliary electric heat or emergency heat capability are not available for the HydroTech units. Safety devices are built into each unit to provide the maximum system protection possible when units are properly installed and maintained.

Caution!

- A 50 degree minimum entering water temperature and sufficient water flow is required to prevent freezing of the heat pump's coaxial heat exchanger.
- HydroTech units should not be operated without an air filter in place. Units should not be operated during building construction due to the potential of excessive dust and debris collecting on the filter and/or the units air coil. Failure to follow this caution could result in equipment damage and void unit warranty.
- Extreme caution must be taken to ensure that no internal damage will result if holes are drilled in the HydroTech cabinet. HydroTech units are approved for installation in indoor applications only. Do not locate units in unconditioned spaces where humidity levels could cause cabinet condensation.
- Remove the shipping block between the blower deck and the bottom of the blower housing. Install filter brackets.
- Units are not internally trapped. An external trap must be installed on the condensate line for proper drainage.
- The condensate drain pan is equipped with an electronic condensate overflow safety device. Prior to unit start up check the overflow sensor for alignment and proper operation. Failure to follow this step could result in equipment and/or property damage.

Proper Heat Pump Sizing

Prior to installing a new HydroTech heat pump in a new or replacement application, a heat gain/loss analysis should be completed to determine the proper heat pump size. Installing an undersized heat pump will result in poor performance and high utility bills. Installing an oversized heat pump will also result in poor performance and high utility bills as well as high humidity levels in the conditioned space. Both scenarios lead to equipment failures and a reduced heat pump life expectancy.

Air Distribution Ductwork

The WSV* and WSH* heat pumps have a duct flange for use in connecting the plenum. Plenum connections must be made to the duct flanges. **Do not** connect the plenum to the outside of the cabinet top. Doing so will create excessive airflow turbulence in the plenum resulting in noisy heat pump operation. First Company recommends air distribution ducts be properly designed and installed in accordance with ACCA manual "D." An improperly sized duct system will lead to improper heat pump operation, higher utility bills, poor cooling and/or heating performance and will lead to premature failure of the heat pump. HydroTech heat pumps are frequently installed as replacements in an existing application. An analysis of the existing duct system should be made prior to installing a new heat pump to insure the new unit will operate properly.

The most common problem encountered with replacement applications is an undersized duct system and/or an oversized heat pump. Heat pumps installed in a replacement application with excessive duct static pressures due to an undersized duct system result in noisy operation, high utility bills, short and frequent operation cycles and most importantly, excessive humidity levels in the conditioned space.

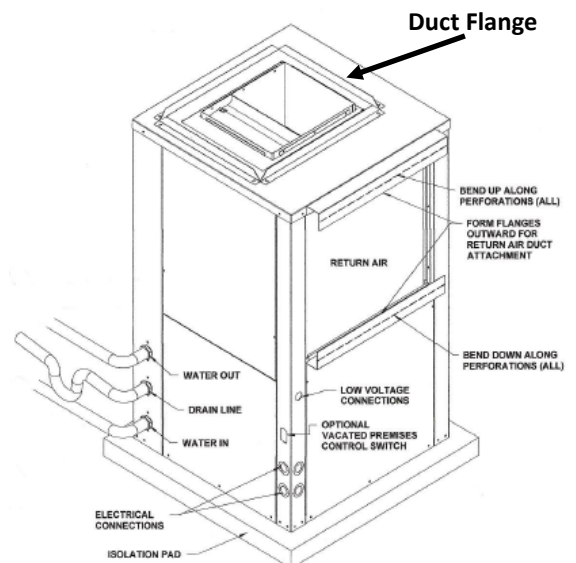

Electrical Connections

Prior to connecting a new HydroTech heat pump to a new or existing electrical service the following items should be checked:

- Supply voltage matches the voltage and phase of the new heat pump.
- Size and condition of the wiring to be connected. (do not use aluminum wiring)
- Size and condition of the circuit breaker. It is recommended to install a new breaker with the new heat pump.
- **Insure the unit is grounded.**

Note: When connecting a new HydroTech heat pump to a 208 volt power supply, the primary leads to the unit transformer must be changed from the 230 Volt to the 208 Volt primary transformer tap.

Thermostat Connections

A standard 24 VAC Heat Pump thermostat is required to operate a HydroTech heat pump.

Following are the thermostat connections:

- C: Transformer 24 VAC Common
- O: Reversing Valve (energized in the cooling mode of operation)
- Y: Compressor Contactor (Y is energized in both cooling and heating modes of operation)
- R: Transformer 24 VAC Hot
- G: Air Coil Blower

Control Module and Safety Devices

Each HydroTech heat pump is equipped with the Control Module that controls the heat pump operation and monitors the safety controls protecting the compressor, coaxial heat exchanger, wiring and other components from damage caused by the unit operating outside the design conditions.

Safety Controls:

- High Pressure Switch: (opens if the high pressure reaches 600 lbs. PSIG)
- Loss of Charge Switch: (opens at 40 lbs. PSIG)
- Coaxial Heat Exchanger Low Temperature Cutout Sensor: (opens at 30 degree water temperature)
- Air Coil Low Temperature Cutout Sensor: (**optional**—opens at 30 degree air temperature)
- Condensate Overflow Protection Sensor: (located in drain pan) Fault code 16

Additional Control Module Features:

- 5 minute anti-short cycle timer: (occurs on start up and when unit is recycled)
- Random Start Feature: 5 to 80 second random start upon power up
- Loss of Charge Bypass Timer: 120 second switch bypass to prevent nuisance low pressure lockouts
- Over / Under Voltage Shutdown: When a over / under voltage condition is detected, the module will initiate a shutdown
Note: Operating range of 18.5 to 31 VAC from transformer secondary. Fault is auto-resetting
- Test Mode: Module enters a 10-minute test mode when test mode pins are momentarily jumped
- Fault Retry: After the 5-minute anti-short cycle timer resets the unit will attempt to restart. After 3 attempts to restart and the fault is still present, the Control Module enters the lockout mode.
- Lockout: To reset the Control Module after a lockout occurs a “soft reset” (cycling the thermostat off and on) or a “hard reset” (disconnecting and reconnecting power) will reset the control module.
- LED Indicators: Two LED indicators are provided: **Green** (proper power present) **Yellow** (unit in the Test Mode)
- Fault LED Display: The two-digit display indicates system faults

Note: See chart at the top of page 4 for the Control Module fault codes.

Cooling Tower Application

To assure optimum cooling and heating performance, the cooling tower water loop temperatures should be maintained between 60 and 95 degrees in the cooling mode of operation and between 55 and 75 degrees in the heating mode. In the cooling mode heat is rejected from the heat pump’s refrigerant into the water loop. A cooling tower provides evaporative cooling to the loop fluid maintaining a constant supply temperature to the heat pump. In the heating mode, heat is absorbed from the water loop into the heat pump’s refrigerant. **Note: If a boiler is not used to maintain a constant water loop temperature, the heat pump may not be able to provide adequate heating to the conditioned space.**

When using an open cooling tower, chemical water treatment is mandatory to insure the water is free of corrosive materials.

Heat Pump Vibration & Sound Isolation

Since the majority of the water-source heat pumps installed in Florida are installed within the living space, quiet vibration-free operation is necessary to insure customers satisfaction. Each application requires careful consideration. Options for insuring a quite operating heat pump include:

- A compressor sound blanket is recommended and should be installed prior to the installation of the heat pump
- A platform with a solid top is recommended to reduce vibration and noise.
- Isolation pads installed between the platform and heat pump base. Armaflex provides an excellent isolation pad.
- Rubber/cork isolation pads installed at each corner of the heat pump base with an additional pad installed between the four corners. In addition a pad should be installed under the base pan below the compressor. This procedure involves 9 separate pads.

Note: It is recommended a open platform with only corner supports not be used as the installation is likely to cause an objectionable “oil canning” or “rumbling” sound. A solid base with an isolation pad is the best option.

System Checkout

After completing the heat pump installation and before energizing the unit, the following system checks should be completed:

- Verify the supply voltage to the heat pump is in accordance with the nameplate ratings
- Ensure all electrical connections are tight and secure
- Check the circuit breaker or fuses are the correct size and the connecting wiring is also the correct size
- Verify the heat pump thermostat is configured properly and the low voltage is correctly connected
- Verify the dip switches on the control module are all set to “off” for standard operation

Note: Dip Switch #1 (8-switch module), position #2 is set to the “on” position for units with ECM motors

- Verify the water piping is complete and leak-free.
- Check condensate overflow sensor for proper positioning—adjust if necessary.
- Verify an external condensate trap has been installed.
- Check water flow rate is correct. Normal flow rate is 3 GMP per ton (12,000 BTU) of cooling.
- Check the blower wheel for free rotation and insure the hub bolt is tight.

System Start-Up

- Set thermostat to its highest setting
- Set thermostat to the “cool” position. The reversing valve solenoid will energize.
- Wait 5-minutes for the anti-short cycle timer to time out
- Adjust the thermostat temperature setting to at least 5 degrees below the room temperature
- Verify the heat pump is running in the cooling mode of operation
- Check the heat pump operation in the heating mode of operation

Operating Temperatures and Pressures

It is recommended that the refrigerant suction and discharge pressures, air coil temperature drop/rise, and condensing water temperatures are checked as part of the heat pump start up procedure. **Note: Since the refrigerant charge is critical on all packaged heat pumps, please use “quick connect fittings” on refrigerant hoses to eliminate lose of refrigerant.** Consult the Installation, Operation, and Maintenance Instruction booklet (packaged with each HydroTech unit) for the operating temperature and pressure guideline for the particular unit installed. After 10 to 15 minutes of operation verify the entering and leaving water temperatures and flow rate. A minimum water flow of 3.0 GPM per ton are required for proper heat pump operation. Find the entering water temperature on the operating temperature and pressure chart and plot the range for the suction and discharge pressures, water temperature rise, and the air coil temperature drop/rise. Both cooling and heating operating temperatures and pressures are listed on the charts. If any irregularities are noted during the unit start-up they must be corrected immediately.

HydroTech Heat Pump Troubleshooting

The HydroTech Water-Source Control Module (WSCM) controls the unit operation and monitors the safety controls to insure the compressor, coaxial heat exchanger, blower motor, wiring and other components are protected. The (WSCM) with its on-board troubleshooting capability is able to alert the technician and provide a specific troubleshooting start point should a problem occur.

The WSCM has the following diagnostic features that advise the technician of the unit's current operational status:

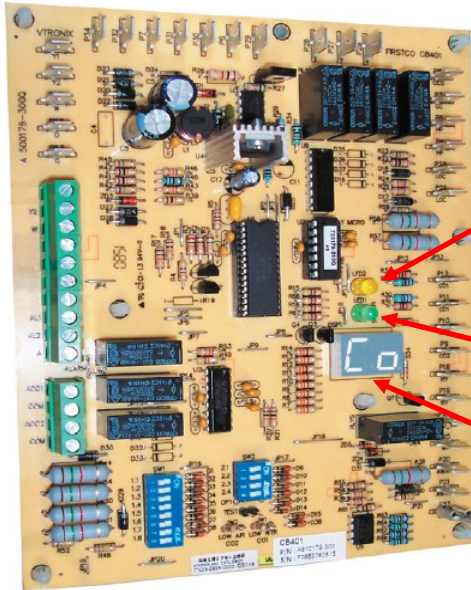

Yellow LED indicates the unit is in the "Test Mode"

(By momentarily shorting the test pins, the WSCM enters a 10-minute Test Mode period)

Green LED indicates that 18.5 to 31.0 VAC is present

Two-Digit LED Display indicates either the current operational mode or the last fault in memory

Digital Control Module

WSCM Codes

Following are the most common codes found during heat pump operation:

ST With power applied to the unit the Green LED should be on with an "ST" showing in the LED readout. The unit is in the Standby mode and is ready to operate. If power is applied and the Green light is off, the unit is not functional and troubleshooting is required.

FO When the fan position is switched to fan "On" the display will read FO.

CO When the system is switched to the "Cooling" mode CO will be shown in the display.

H1 With the system in the "Heating" mode H1 will appear

11 Code 11 indicates there is no fault

12 Code 12 indicates a High Pressure fault (**600 lb trip**)

13 Code 13 indicates a Low Pressure fault (**40 lb trip**)

14 Code 14 indicates CO1 (low water temp sensor) is either faulty or out of range (cutout is set at 30 degrees)

15 Code 15 indicates CO2 (optional air temp sensor) is either faulty or out of range

16 Code 16 indicates the condensate drain line is plugged or running slow

17 Code 17 indicates an "over" or "under" voltage shutdown (this is an auto-reset fault)

18 Code 18 indicates the CO1 and CO2 temperature sensor connections are reversed

19 Code 19 indicates the CO1 sensor is jumpered or the CO1 or CO2 circuit is "open" (verify jumper on CO2 terminals is present)

CONTROLLER FAULT CODES	
DESCRIPTION OF OPERATION	LED Readout
NORMAL MODE	ON (Green Light)
CONTROLLER NON-FUNCTIONAL	OFF (Green Light)
TEST MODE (pins shorted momentarily)	ON (Yellow Light)
STANDBY	St
FAN ONLY (G active)	Fo
COOL (Y1 & O active)	Co
HEAT 1st STAGE (Y1 active)	H1
ACCESSORY RELAY 1	A1
ACCESSORY RELAY 2	A2
VACATED PREMISES CONTROL	Ay
FAULT RETRY	rE & CODE #
LOCKOUT	Lo & CODE #
OVER / UNDER VOLTAGE SHUTDOWN	Ou & CODE #
TEMPERATURE SENSOR ERROR	SE & CODE #
TEST MODE - NO FAULT	CODE 11
TEST MODE - HP FAULT	CODE 12
TEST MODE - LP FAULT	CODE 13
TEST MODE - CO1 FAULT	CODE 14
TEST MODE - CO2 FAULT	CODE 15
TEST MODE - COND. OVERFLOW FAULT	CODE 16
TEST MODE - OVER / UNDER SHUTDOWN	CODE 17
TEST MODE - SWAPPED CO1 / CO2 THERMISTORS	CODE 18
TEST MODE - TEMPERATURE SENSOR ERROR	CODE 19

WSCM Code Continued: Fault Code Not Listed?

On a rare occasion a fault code will appear in the 2-Digit display that is not listed on the chart on the preceding page. In the majority of these situations we’ve found the heat pump thermostat was not properly configured. In other situations we’ve found a low voltage wiring problem (short or open) between the thermostat sub-base and the WSCM low voltage terminal block. In order to pinpoint the source of the problem verify the Green LED on the WSCM is on. Remove the thermostat and jumper the low voltage wiring at the sub-base. If the problem is eliminated, verify the thermostat is configured and is operating properly. If the problem persists, disconnect the low voltage wiring from the WSCM and apply jumper wires from R to Y1, O, and G. If the problem is eliminated, locate and repair the low voltage wiring problem.

Fault Retry Mode:

While in the Fault Retry Mode the LED will display a code “re” representing “retry” and the fault code two-digit number. The unit will initiate the Anti-Short Cycle timer and try to restart after the delay. If three consecutive faults occur without satisfying the thermostat the WSCM will go into Lockout Mode. The last fault causing the lockout will be stored in the memory and be displayed.

Sensor and Safety Inputs:

All sensor and safety control inputs are paired wires connecting each component to the Control Module. The High and Low pressure switches can be checked by disconnecting one spade clip and checking continuity. The CO1 (low water temperature) and CO2 (low air coil temperature—if used) must be checked with an Ohm meter. One spade clip must be removed to obtain an accurate Ohm reading. Once the Ohm reading is taken, compare the reading with chart to the right. The thermistor Ohm value should fall within plus or minus 3% of the Ohm values listed. The thermistor can also be submersed in an ice bath to verify the calibration.

Temp. (F)	Temp. (C)	Resistance (kOhm)	Temp. (F)	Temp. (C)	Resistance (kOhm)
0.0	-17.8	85.41	71.6	22	11.42
1.5	-16.9	81.43	73.4	23	10.92
10.4	-12	61.70	75.2	24	10.45
14.0	-10	55.30	77.0	25	10.00
17.6	-8	49.60	78.8	26	9.57
21.2	-6	44.60	80.6	27	9.17
23.0	-5	42.30	82.4	28	8.78
24.8	-4	40.10	84.2	29	8.41
26.6	-3	38.10	86.0	30	8.06
28.4	-2	36.10	87.8	31	7.72
30.2	-1	34.30	89.6	32	7.40
32.0	0	32.60	91.4	33	7.10
33.8	1	31.00	93.2	34	6.81
35.6	2	29.40	95.0	35	6.53
37.4	3	28.00	96.8	36	6.27
39.2	4	26.60	98.6	37	6.02
41.0	5	25.30	100.4	38	5.78
42.8	6	24.10	102.2	39	5.55
44.6	7	23.00	104.0	40	5.33
46.4	8	21.90	105.8	41	5.12
48.2	9	20.80	107.6	42	4.92
50.0	10	19.90	109.4	43	4.73
51.8	11	18.97	111.2	44	4.54
53.6	12	18.09	113.0	45	4.37
55.4	13	17.25	114.8	46	4.20
57.2	14	16.46	116.6	47	4.04
59.0	15	15.71	118.4	48	3.89
60.8	16	15.00	120.2	49	3.74
62.6	17	14.32	122.0	50	3.60
64.4	18	13.68	123.8	51	3.47
66.2	19	13.07	125.6	52	3.34
68.0	20	12.49	127.4	53	3.22
69.8	21	11.94	129.2	54	3.10

WSCM Field Inputs:

All inputs to the board are 24 VAC from the thermostat and can be verified using a voltmeter between “C” (common) and Y1” (compressor contactor), “O” (reversing valve—energized in the cooling mode) and “G” (blower).

WSCM Field Outputs:

The following functions and relay can be verified by using a voltmeter across the terminals as indicated below:

- The compressor relay can be verified by measuring 24 VAC across terminals “CC” and “CCG” with a “Y” signal.
- The fan relays on the WSVC and WSHC models can be verified by measuring across terminals, “G1 & C” and on the WSVX and WSHX measuring across terminals “G2 & C” after 40 seconds in the Test Mode.

Blower Speed Selection

HydroTech Heat pumps are set at the factory to deliver the rated airflow at a nominal external static pressure of .30 in. wg. Heat pumps have an on-board dehumidification function that allows the blower to operate in the cooling mode on low speed for approximately 10 minutes. After operating on low speed for the prescribed amount of time, the Control Module increases the blower speed to high-speed for the remainder of the cooling cycle. In applications where additional airflow is required or the duct system static pressure is higher than normal, the blower speed (CFM) can be adjusted. All HydroTech heat pumps have 4-speed blower motors, which can be field-modified to a higher CFM when additional airflow is required. Blower speeds are changed on the WSVC /WSHC (13.0 EER) heat pump models by switching the motor speed wiring at the “blower speed relay” located in the control panel. See diagram below:

WSVC & WSHC Blower Wiring

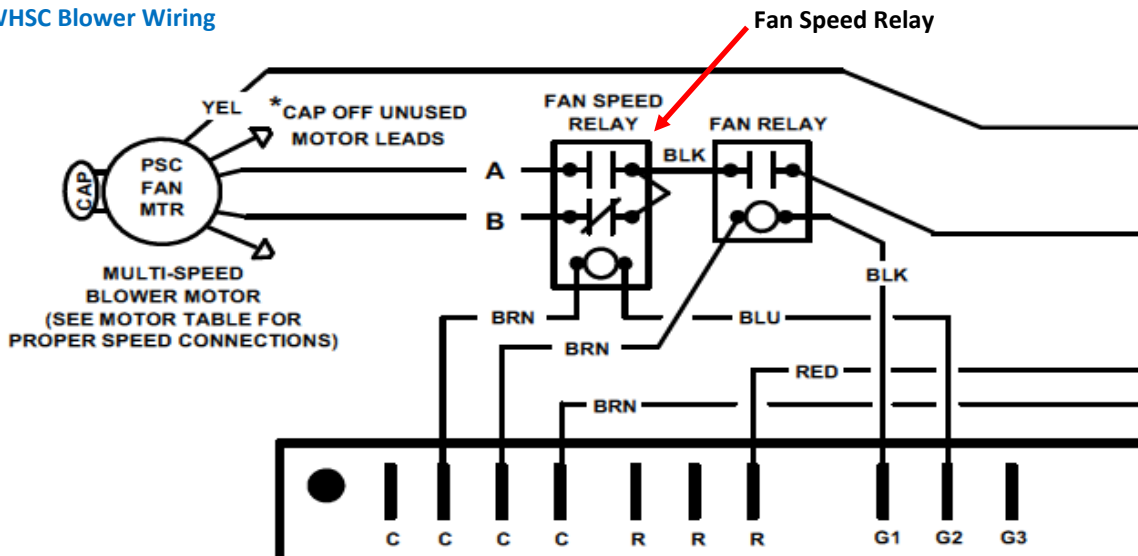

Blower speeds for the WSVX / WSHX (14.0 EER) heat pump models are changed on the ECM motor taps located on the motor module. See diagram below:

WSVX & WSHX Blower Wiring

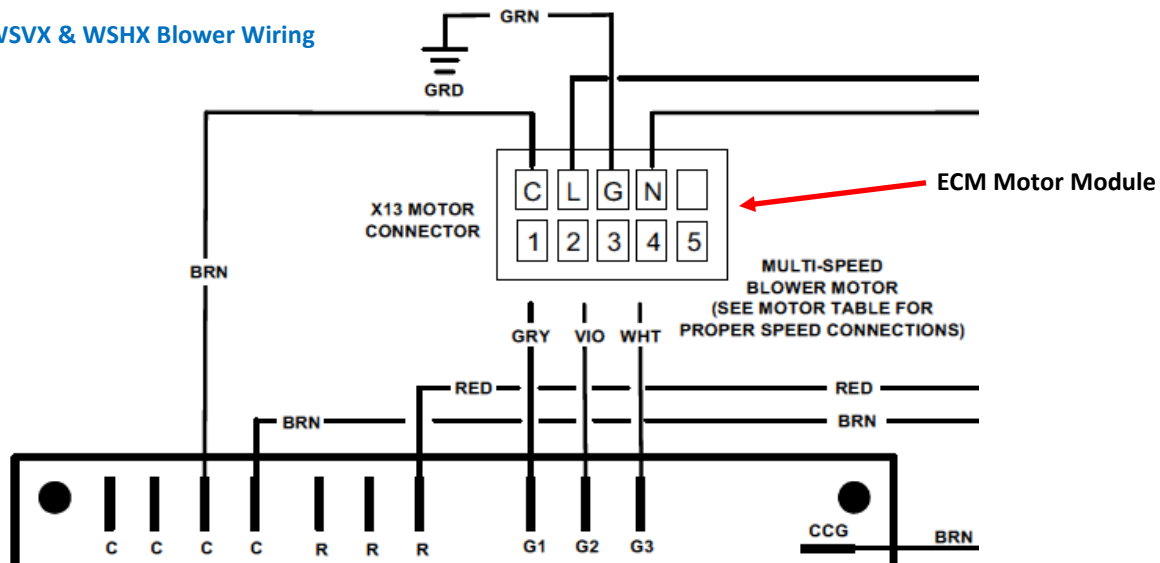

NOTE: Speed tap #5 on the motor module is not programmed

Refer to the HydroTech Installation, Operation, and Maintenance Instructions for more information.

PROBLEM or FAULT	HTG	CLG	POTENTIAL CAUSE	ACTION
Unit won't start when power is applied. Green status light off	X	X	230 VAC not applied	Verify 230 VAC power is applied to contactor
			Transformer	Ohm out transformer primary & secondary
			Circuit Board	Green light off when 24 VAC is applied, board failed Green light on--unit is ready to start
			Thermostat	Check thermostat and low voltage wiring
FAULT CODE 11	X	X	No Faults Present	Unit Operational
FAULT CODE 12 High Pressure Switch Trip		X	Low or no water flow	Verify 3.0 GPM per ton water flow rate is present
		X	Restricted heat exchanger	Back flush or replace coaxial heat exchanger
		X	Inlet water temp too high	Reduce supply water temp (range = 50/100 degrees)
	X		Reduced or low air flow resulting in higher than normal supply air temps	Check air filter
				Check condition of air coil--clean as necessary
				Check external duct static pressure
				Increase blower CFM
		X	X	Non-condensables
	X	X	System over charged	Recover refrigerant and weigh in correct charge
	X	X	Faulty H/P Switch	Verify wiring is OK, replace switch
FAULT CODE 13 Loss of Charge / Low Pressure Switch Trip		X	Low refrigerant charge	Check for restriction in refrigerant system
				Check air filter
				Check condition of air coil--clean as necessary
				Check external duct static pressure
		X		Low cond water flow
	X		Inlet water temp too low	Increase supply water temp (range = 50/100 degree)
FAULT CODE 14 Low Water Temperature Cut Off	X		Low water flow	Verify 3.0 GPM per ton water flow rate is present
				Back flush or replace coaxial heat exchanger
		X	Water temp too low	Increase supply water temp (range = 50/100 degrees)
		X	X	Faulty thermister
FAULT CODE 16 Condensate Overflow	X	X	Plugged condensate drain	Clear condensate drain line
	X	X	Improper trap	Verify trap location and dimensions
		X	Poor drainage	Verify the drain line has proper slope
		X	Moisture on sensor	Moisture on sensor can short the sensor to ground
FAULT CODE 17 Over / Under Voltage (Auto-Resetting)	X	X	Over/Under Voltage	Check power supply and 24 VAC
				Verify wiring is the proper size
				Check compressor start amps. Need start kit?
				Check transformer primary tap for 230 or 208 VAC
FAULT CODE 18 Sensor (thermister) Fault	X	X	Swapped CO1 & CO2	Reverse thermister connections on WSCM
FAULT CODE 19 Sensor (thermister) Error	X	X	CO1 or CO2 Mis-wired	CO1 is faulty or has been jumpered
				CO2 jumper is missing or jumper is "open"

Thermal Expansion Valve

The role of the TXV is to control liquid refrigerant injection into the evaporator as a function of the load. The controlling parameter is superheat at the evaporator coil. As the load on the evaporator coil increases, the valve responds to an increase in superheat and opens to allow more liquid refrigerant to flow into the evaporator coil.

The TXV consists of three primary parts: The power head, the capillary tube and bulb, and the body. The capillary tube and bulb (containing a charge) are connected to the power head. As the pressure in the capillary tube and bulb expands and contracts it exerts a varying pressure on the diaphragm working against the spring pressure located in the bottom section of the valve. The pushpin regulates the opening of an orifice through which the refrigerant is metered into the evaporator coil.

The function of the TXV depends on the relationship between three fundamental pressures. The bulb pressure (1) acts on the upper surface of the diaphragm, moving it in the valve-opening direction. Two pressures oppose the sensing bulb pressure. Evaporator pressure (2) is introduced by the internal (or external) equalization. This equalization pressure acts on the underside of the diaphragm in the valve-closing direction. Spring pressure (3) also acts on the underside of the diaphragm in the closing direction. As the expansion valve regulates, there is balance between “bulb pressure” on one side of the diaphragm and equalization pressure plus spring pressure on the other side. The TXV pressure balance is affected with a change in the cooling load on the evaporator coil. A change in the cooling load will change the evaporator pressure of the refrigerant and hence the equalization pressure under the diaphragm. This change occurs in proportion to the change in temperature at the evaporator outlet tube where the sensing bulb is strapped. Any change in pressure is transmitted from the bulb through the capillary tube to the top of the diaphragm. As the load on the evaporator increases pressure is exerted on top of the diaphragm causing the valve to move further toward the open position. In the same manner, when the load on the evaporator decreases the pressure on top of the diaphragm is reduced allowing the spring pressure to move the valve toward the closed position.

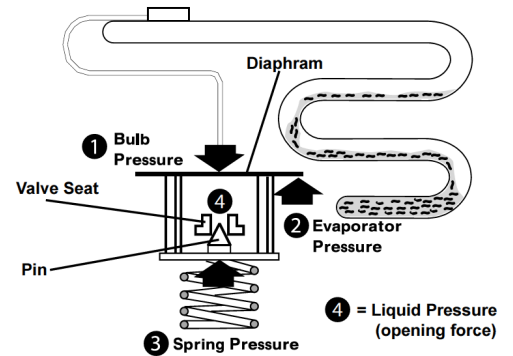

The Bi-Flow TXV

The bi-flow TXV is a relatively new expansion valve type for the HVAC industry. Its use is restricted to package units since the evaporator and condenser must be physically located in close proximity to one another with the sensing bulb located on the common suction line—near the reversing valve on the center tube. Use on split systems is impractical due to the distance between the evaporator and condenser. The bi-flow TXV's are an excellent fit for HydroTech heat pumps as they meter the flow of refrigerant in either direction without the need for check valves. The primary refrigerant flow direction, marked with an arrow on the valve body, is determined by the primary function of the heat pump; cooling or heating.



TXV Troubleshooting

The TXV performs only one simple function—to keep the evaporator supplied with enough refrigerant to satisfy all the load conditions. If too little refrigerant is being fed to the evaporator the superheat will be high. If too much refrigerant is fed to the evaporator coil the superheat will be too low. Often these symptoms are attributed to improper TXV operation when the source of the problem is often elsewhere.

The TXV cannot accurately be checked without verifying the airflow is correct. Duct sizing (external static pressure), blower speed, and filter condition all affect the air flow of the heat pump. Poor airflow will look like a system undercharge. Verify proper airflow prior to troubleshooting the TXV.

Simple TXV Operational Test

If the TXV is suspected of no longer metering refrigerant the following simple test should be accomplished before condemning the valve. With the system operating, remove the TXV sensing bulb from the unit's suction line and warm it up by tightly holding it while watching the suction pressure. In response, the suction pressure should increase. Further testing can be done by immersing the sensing bulb in ice water, which should result in a decrease in the suction pressure. No change in the suction pressure would indicate a non-responsive TXV.

TXV Troubleshooting Quick Reference Guide

SYMPTOM	Suction Pressure	Discharge Pressure	Superheat	Subcooling	Compressor Amperes
System Overcharge	High	High	Normal to Low	High	High
Non-condensable in system	High	High	Low	Low	High
Coaxial Heat Exchanger Restricted	High	High	Low	Low	High
System Undercharge	Low	Low	High	Low	Low
Liquid Line Restriction	Low	Low	High	High	Low
Suction Line Restriction	Low	Low	High	High	Low
Inefficient Compressor	High	Low	High	High	Low
TXV is stuck almost closed	Low	Low	High	High	Low
TXV is stuck open	High	Low	Low	Low	Low

Reversing Valves

The reversing valve provides the ability to switch functions of the two heat exchangers; the evaporator air coil and the coaxial heat exchanger. The discharge line from the compressor is always connected to the bottom of the reversing valve. The center line at the top of the reversing valve is always connected to the compressor suction line. The remaining two connections allow the heat pump to switch from the heating to the modes of operation. The normal (non-energized) mode of operation is heating. The reversing valve is a “pilot-operated” valve, which means that the solenoid opens a small port, connecting the tubing from the bottom port (discharge line from the compressor) to the valve chamber. The high pressure of the discharge line forces the valve to switch from one mode to the other.

Reversing Valve Troubleshooting

Heat pump reversing valve failures are often confused with compressor failures. Since the replacement of a reversing valve is a difficult task, it's important to correctly diagnose a failure so a valve is not replaced unnecessarily. Weak compressor valves and a reversing valve internally bypassing refrigerant are both usually characterized by a high suction pressure and a lower-than-normal high-side pressure. In addition the system capacity is reduced. One additional malfunction that can give a similar symptom is a liquid bypass—high side refrigerant passing to the system's low side. This liquid bypass could be caused by a TXV that is partially (or fully) stuck open or, with piston-metered refrigerant systems, a poorly seated fixed piston.

1) Determine if the evaporator coil is flooded with liquid refrigerant. If the evaporator coil is flooded, the problem is most likely a liquid bypass. A TXV system with a liquid bypass will have a low superheat, lower than the normal 8 to 12 degrees. In fact the superheat could be as low as “0”. Once its determined there is no liquid bypass, move to the next step.

2) “Hot wire” the reversing valve solenoid (24 Volt) so that it is energized all the time. Disable the condenser fan motor and start the heat pump in the *heating* mode of operation. Allow the head pressure to rise until it reaches 475/500 lbs. then turn the system off.

3) Increasing the pressure in the system intensifies the hot gas bypass symptom making it easier to identify. Listen for a “hissing” noise from the source (reversing valve or compressor) of the hot gas bypass. If the hot gas bypass location isn't obvious by sound, place one hand on the compressor dome at the suction line and the other hand on the suction line as it exits the reversing valve. Either the compressor suction line or the reversing valve suction line will most likely heat up quickly, identifying the source of the hot gas bypass.

4) If the compressor gets hot quickly, the compressor is the source. If, on the other hand, the reversing valve gets hot quickly, it will be the source of the hot gas bypass. If it is still difficult to tell which component is responsible for the hot gas bypass, the compressor is most likely the source. If the compressor is bleeding, it may be difficult to tell easily, however, if the reversing valve is bleeding, it will be easy to identify due to its small size. One additional consideration; a compressor with weak valves may not yet have hot gas bypass. Again, if the reversing valve is good, the compressor is likely the source of the problem.

Note: Taking temperature readings across the reversing valve inlet/outlet ports is not a reliable procedure to determine if hot gas bypass is present.

Electronically Commutative Motor (ECM)

First Company employs two motor types on the HydroTech heat pumps; the traditional permanent split capacitor (PSC) and the X13. The PSC motors are used on the WSVC and WSHC heat pumps while the X-13 motors are used on the WSVX and WSHX models. The X-13 (or constant torque) high-efficiency motors are used by First Company in place of PSC motors when working toward a higher product efficiency rating such as the WSVX/WSHX heat pumps.

The X-13 motors are high-efficiency, brushless DC motors that are controlled by 24-volt signals. Motors are programmed at First Company for each specific HydroTech heat pump model. The X-13 motors are programmed to deliver constant torque, not speed or CFM. Motors used on the HydroTech heat pumps have programming applied to taps 1 through 4; tap 5 is not programmed. The X-13 motor offers several benefits such as increased SEER ratings resulting in lower energy bills. In addition they are slightly quieter and traditional PSC motors and contribute to a slight improvement in dehumidification.

Over the past few years the X-13 motors have gained some negative press due to, in some cases, a higher than normal failure rate in the field. While some of the failures resulted in electronic component failures (located in the motor module) other failures were/are caused by external factors according to motor manufacturers. Following are several potential “external” motor failure causes and solutions:

<u>Symptom</u>	<u>Potential Cause</u>	<u>Solution</u>
Excessive moisture (wet motor and/or blower)	Blower compartment too cold	Verify all supply and return registers and grills are open Check for dirty evaporator coil Check blower motor speed tap—increase as needed
Poor air delivery	Duct system with high static	Check external static—reduce as needed to bring in range
Motor burnout	Lightning	Verify the heat pump unit is grounded Motors susceptible to strikes (install surge protector)

Dirty power usually originates outside of a condominium building and can cause an X-13 motor failure. Dirty power is a term used in the HVAC industry to describe a surge, a sag, a spike, a transient, a fluctuation, an interruption, or noise. As an example, utility switching, capacitor switching, and faults on the utility company’s distribution system can affect the quality of power before it reaches the heat pump unit. These problems are difficult to determine without the help of the local utility company.

Compressors, Capacitors and Hard Start Kits

Single phase compressors typically have starting inrush currents that range from five to seven times their normal running current. A hard start kit is designed to reduce that inrush current to the compressor by up to 75%. A hard start kit consists of a mechanical potential relay connected to a start capacitor that’s wired to the compressor to aid its start-up. Start kit benefits include a reduction in perceived light flicker, better starting during low voltage and/or dirty power conditions, efficient starts for systems with undersized wiring, quick starts for systems with a pressure differential on start-up and start kits provide longer contactor life. In addition, the older a system becomes the greater the benefit of adding a hard start kit. These challenges make hard start kits a great potential aftermarket sales item. First Company recommends using only “3-wire” hard start kits only for use on the HydroTech heat pumps. The “start assist” products on the market are not recommended.

First Things, First

Prior to installing a hard start kit (unless it’s a new installation), two items must be checked first—the run capacitor and the contactor. A weak run capacitor or a contactor with excessive pitting will cause the unit to operate with higher amperage than designed and will, of course, shorten the compressor’s life. The contactor should be checked visually for excessive pitting and wear.

Run Capacitor Test

Bench Test

1. Turn off power to the unit
2. Mark the location of each wire on the run capacitor and remove it
3. Using a test instrument check the MFD rating of the capacitor when unloaded
4. If it is +/- 10% of the stated rating, replace the capacitor

Running Unit Capacitor Test (most accurate)

1. Start unit in the cooling mode
2. Check and record voltage on the run capacitor between the Common and Start terminals
3. Check and record the amp draw on the common wire feeding the run capacitor
4. Using the formula below, determine the MFD the run capacitor is producing
 $2650 \text{ (constant)} \times \text{amp draw across the run capacitor, divided by the voltage at the capacitor} = \text{capacitor output}$
Example: 30 MFD @ 370 VAC Capacitor test
Voltage on the run capacitor between Common and Start = 300 VAC
Amp draw on the common wire feeding the capacitor = 3.25 Amps
First: $2650 \times 3.25 = 8612$
Then: Divide 8612 by 300 VAC = 28.70 MFD
5. If the measured MFD rating is +/- 5% of the capacitor's marked rating, replace the capacitor

What if a Compressor Doesn't Start?

In a situation where a HydroTech compressor doesn't start, First Company recommends a "Locked Rotor Pull-Down Voltage" (LRPDV) test is performed on the compressor before making the replacement. Following are the test steps:

1. Check and verify the wire sizing to the unit is correct, check the circuit breaker, check all electrical connections making sure they are tight and corrosion-free prior to moving ahead with the test procedure
2. Record the voltage at the contactor
3. Turn off power to the unit
4. Disconnect the start terminal from the run capacitor (tape the spade clip for safety)
5. Connect a voltmeter to the compressor side of the contactor between Common and Run
6. Replace the compressor terminal cover
7. Attempt to start the unit; The compressor will try to start but will draw locked rotor amps since the run capacitor is out of the circuit
8. Be prepared to read the voltage quickly—the compressor overload may trip after a few seconds
9. Record the minimum voltage as the compressor tries to start. If the voltage drops below 197 volts for a 208/230 volt single phase compressor, the power supply to the unit is insufficient and will need to be corrected.
10. If the test results are positive the next step is to install an approved 3-wire hart-start kit

HydroTech Refrigerant Charging

When a HydroTech heat pump is suspected of having an incorrect charge, First Company recommends recovering the existing charge, evacuating the system, replacing the liquid line dryer, and weighing-in the correct charge. Since charging a package heat pump is critical, this is the only accurate way of being assured the charge is correct.

Typical Operating Parameters

Following are the normal or typical **cooling** operating guideline for the HydroTech heat pumps:

Evaporator air temperature	80 db / 67 wb
Cond water flow rate	3 GPM per ton
Cond water entering temperature	70 to 100 degrees
Cond water leaving temperature	8 to 12 degrees warmer
Evap coil discharge air temperature	58 to 65 degrees
Suction line temperature (with superheat)	65 degrees
Superheat at the compressor	8 to 12 degrees
Discharge line temperature	140 to 165 degrees
Condensing temperature	105 to 110 degrees
Subcooling temperature	10 to 12 degrees
Loss of charge cut-out / cut-in	40 / 80 psig
High pressure cut-out / cut-in	600 / 500 psig

Customer: _____ HydroTech Model: _____
 Address: _____ City: _____ Serial Number: _____
 (1 letter) – (2 numbers) – (1 letter) – (6 numbers)
 Date: _____ Servicing Dealership: _____ Technician: _____

Accessories: Hard Start Kit-Type / Brand: _____ Compressor Cover Vacated Premises Switch
 Voltage: _____ Transformer Primary Voltage Tap: 208 230 Secondary Voltage: _____ Unit Grounded?
 Minimum Circuit Amps: _____ Maximum Overcurrent Amps: _____ Circuit Breaker Size: _____

Step 1

Blower Motor Information:

Motor Voltage: _____ Amps: _____ Cooling Speed: _____ Heating Speed: _____

Step 2

Heat Exchanger Temperatures:

Cond Entering Water Temp: _____ Cond Leaving Water Temp: _____ Cond Temp Rise: _____ GPM: _____

Step 3

Evaporator Coil Temperatures:

Evaporator Coil EAT Dry Bulb: _____ Evaporator Coil LAT Dry Bulb: _____ Delta: _____

Evaporator Coil EAT Wet Bulb: _____ Evaporator Coil LAT Wet Bulb: _____ Delta: _____

Step 4

Compressor Volts: _____ Amps: _____ Discharge Line Temp: _____

Step 5

Refrigerant Pressures / Temperatures: (charge is critical, use refrigeration gauge hose quick connect fittings)

Low Side PSIG: _____ { Vapor Line Temp: _____ **minus** Saturated Temp: _____ = _____ degrees of **Superheat**}

High Side PSIG: _____ { Saturated Temp: _____ **minus** Liquid Line Temp: _____ = _____ degrees of **Sub-cooling**}

Control Module Switch Positions

Dip Switch #1

off / on

Switch # 1.1 Comp Start Delay
 Switch # 1.2 Off "C" Model On "X" Model*

- Switch # 1.3 Blower Time Delay
- Switch # 1.4 Dehumidification
- Switch # 1.5 Off (not programmed)
- Switch # 1.6 Off (not programmed)
- tors
- Switch # 1.7 Vacated Premises Timing
- Switch # 1.8 Off (not programmed)

Control Module Fault Code: _____
 Unit

Dip Switch #2

off / on

Switch # 2.1 Accessory Relay #1 Activation
 Switch # 2.2 60 Second Pre-Compressor Initialize (water valve)
 Switch # 2.3 Accessory Relay #2 Activation
 Switch # 2.4 30 Second Post Fan Delay (off no delay-on 30 sec)

* Switch 1.2 must be in the "On" position for units with X-13 mo-

Note: See Control Module App and Op Manual for more information

To Clear Fault Memory: Enter and Exit Test Mode *or* Reset 230 Power to

NOTES:



FIRST CO. HydroTech™
WATER SOURCE HEAT PUMP LIMITED WARRANTY – FLORIDA

First Company HydroTech™ water-source heat pumps sold and installed in the State of Florida that were installed on or after 4/1/2012 (invoice copy required to validate warranty) are warranted to the original owner to be free from defects in material and workmanship under normal use and maintenance for a period of five (5) years from the date of original installation. This limited warranty includes coverage for the compressor, refrigeration system components (including evaporator coil and heat exchanger) and electrical components. A new or rebuilt part to replace any defective part that fails within the warranty period will be provided when the defective part is returned to the factory. The replacement part assumes the unused portion of the warranty. **This warranty applies to all 208-230V single phase models installed in residential applications only.**

This warranty does not include labor or other cost incurred for diagnosing, repairing, removing, installing, shipping, servicing or handling of either defective parts or replacement parts. In addition, this warranty does not cover and First Co. will not be responsible for:

1. Normal maintenance.
2. Shipping or handling damage.
3. Damage or repairs required as a consequence of faulty installation or misapplication of the product.
4. Failure of the product to operate due to voltage being more than plus or minus 5% of rated voltage, blown fuses, open circuit breakers, or other damages due to the inadequacy or interruption of electrical service.
5. Damage or repairs needed as a consequence of any misapplication, abuse, improper servicing, unauthorized alteration, or improper operation.
6. Damage as a result of fire, flood, high winds, lightning, or other acts of nature, corrosion or other destructive environmental conditions, or other conditions beyond First Co.'s control.
7. Operation of equipment outside the parameters described in the product bulletin.
8. Any indirect, consequential, property, or commercial damage of any nature whatsoever.

WARNING TO INSTALLER, SERVICE PERSONNEL, AND OWNER

Altering a First Co. product or replacing parts with non-authorized parts voids all warranty or implied warranty and may result in adverse operational performance and / or a possible hazardous safety condition to service personnel and occupants. First Co. employees and / or agents are not authorized to waive this warning.

Limitations of warranty - This warranty is exclusive and in lieu of all other warranties express or implied. The remedies provided for in this warranty are exclusive and shall constitute the only liabilities on the part of First Co.

For Service or Repair, Follow these steps:

First: Contact the installer of the equipment or licensed service company

Second: Contact the distributor

Third: Contact First Co.

Maintenance for all First Co. products is available under "Product Maintenance" at www.firstco.com

WSW-F7112